

Spare Parts & Accessories of Hard Fibre or Sisal Machinery

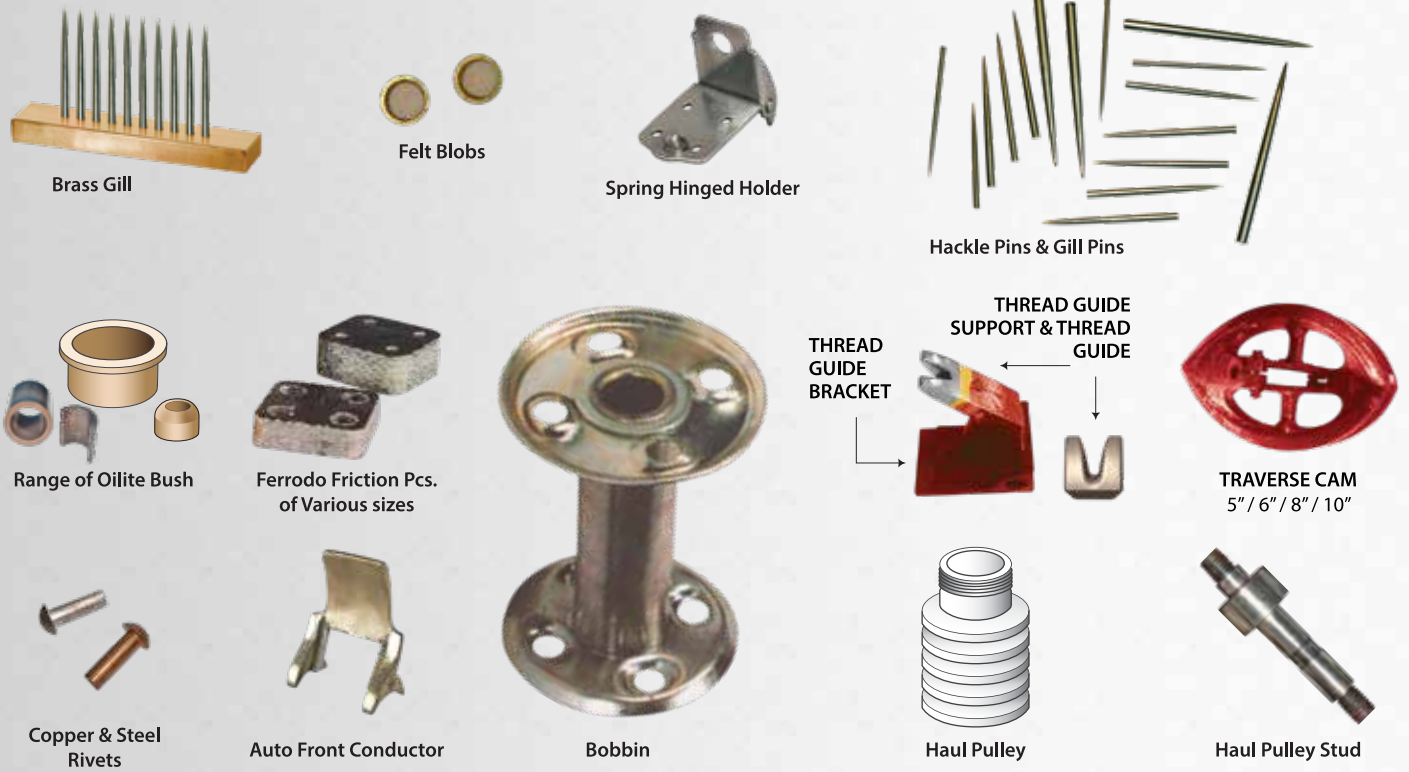

Fast Moving Consumables Of Various Hard Fibre (Sisal) Machinery



40H Hard Fibre James Mackie Machine

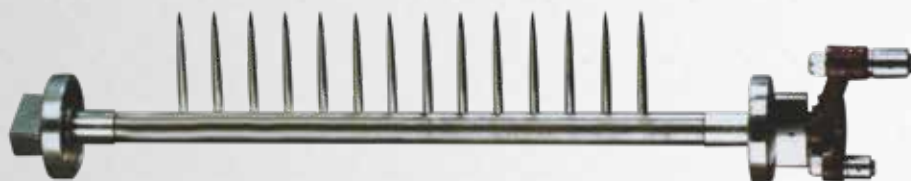

Faller Bar for Mackhigh Goods Machine



Faller Crank
40H 266 L/R



Front Carrier Sprocket
on fast Section (5T)
40H 257 L/R



Front Carrier Sprocket
on fast Section (6T)
40H 257 L/R



Sprocket Runner
40H 261



Spacing Washer
40H 262

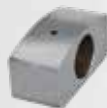

'A'Track Runner
40H 263



'B'Track Stud
40H 269



Clock Worm Wheel
40H 368



Slow Chain Dogs
40H 526 L/R



Slow Chain Up Curve
40H 520 L/R



Slow Chain Down Curve
40H 522 L/R

4H INCLINED HARD FIBRE DRAWING FRAMES

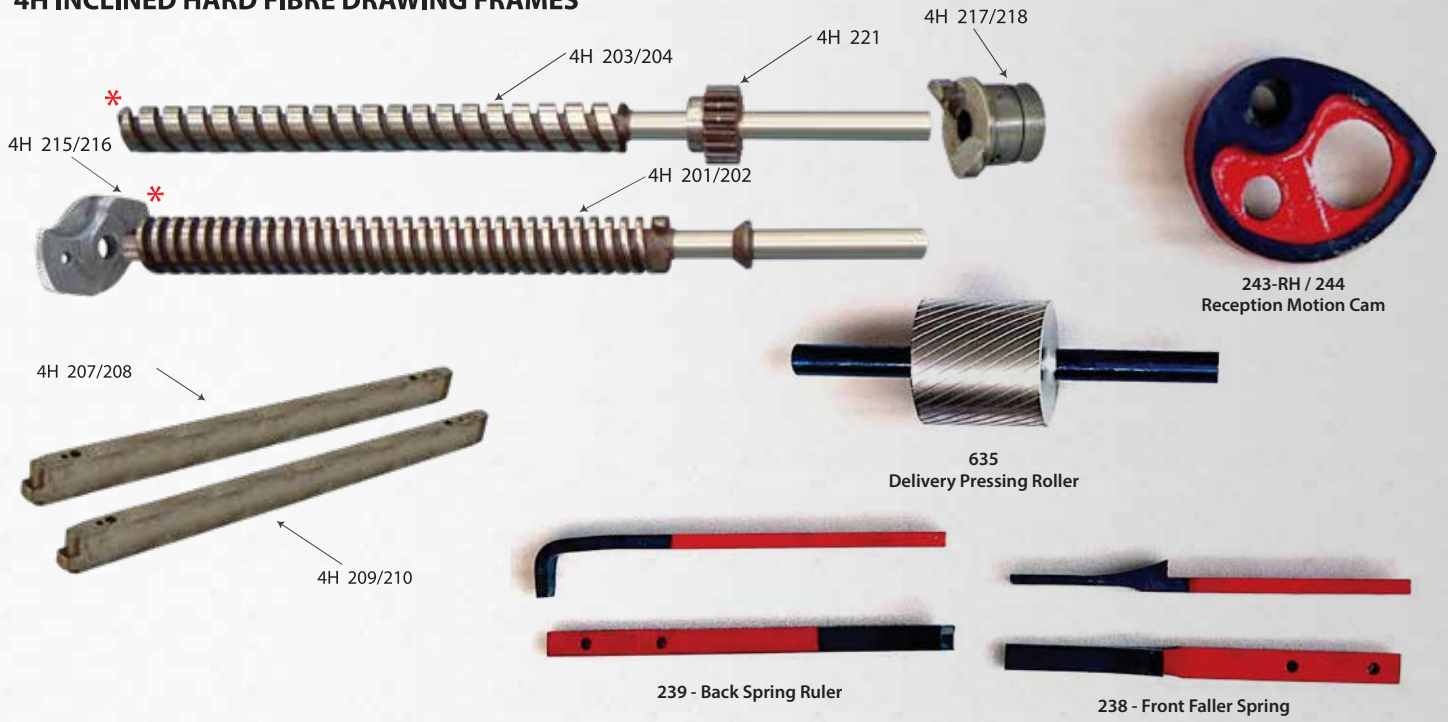

SPINNING SECTION

Friction Base Assembly



18H MACKHAUL / SUPERHAUL GILL SPINNING FRAME & 39H MACKHAUL TWISTING FRAME

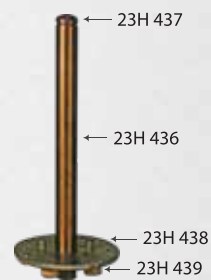

23H TAPE DRIVEN GILL SPINNING FRAME

Flyer Housing Assembly

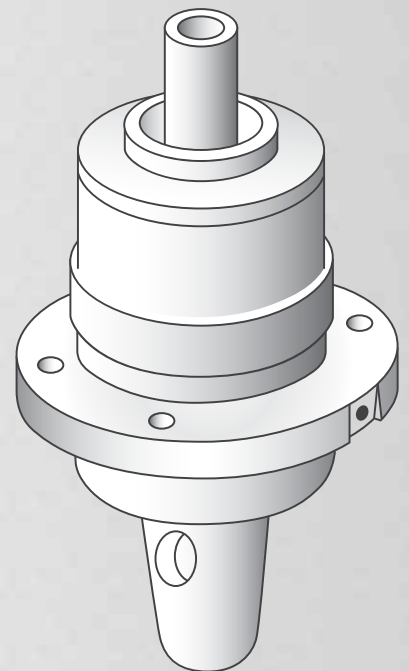

18H MACKHAUL / SUPERHAUL GILL SPINNING FRAME 13" x 9 3/4"

Flyer Assembly

18H 348
24H 325



18H MACKHAUL / SUPERHAUL
GILL SPINNING FRAME

24H DOUBLE ROW
GILL SPINNING FRAME



23H TAPE DRIVEN GILL SPINNING FRAME



Centre Tube Pinion
18H 328



Centre Tube & Pinion
18H 1138



Pressing Roller Flange
18H 735
23H 308
24H 738

5H BALER AND BINDER TWINE SPOOLING MACHINES



TRAVERSE LEVER
Part No. 5H 31



THREAD
GUIDE
BRACKET
Part No. 5H 48

THREAD GUIDE
SUPPORT & THREAD
GUIDE
Part No.
5H 49



TRAVERSE CAM
Part No. 5H 29
5" / 6" / 8" / 10"



SEGMENT
Part No 5H 32

ZUVONTM
PINS & PINNED PRODUCTS

Better Engineering
For Better Fiber

Bajaj Industries Private Limited
P-16 Sahitya Parishad Street
Kolkata - 700 006 (India)

Tel & Fax : +91 33 2555 4048
e : contact@zuvongroup.com
www.zuvongroup.com